

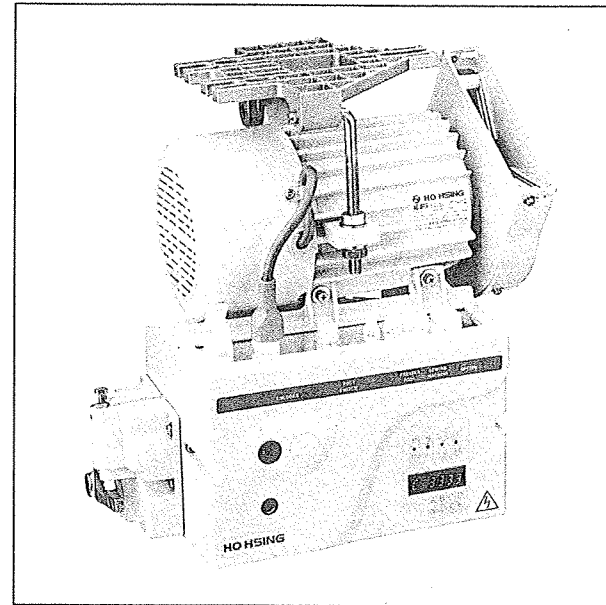

AC 伺 服 馬 達  
AC SERVO MOTOR

使 用 說 明 書  
OPERATION MANUAL

**MODEL : HVP-90 SERIES**



中 文 版

ENGLISH

From the library of: Diamond Needle Corp

MODEL : HVP-90 SERIES  
CONTENTS

	Page
<b>1. Safety Precautions</b> .....	1
<b>2. Installation and Adjustment</b>	
2.1 Motor installation .....	2
2.2 Installation diagram .....	2
2.3 Adjustment on the belt cover .....	3
2.4 Install and adjust the synchronizer .....	3
2.5 Speed control unit adjustment .....	3
<b>3. Power Connection and Grounding</b>	
3.1 Single phase and three phase connection .....	4
3.2 Connect a 1 $\phi$ / 220V power from a 3 $\phi$ / 380 V power source .....	4
3.3 The load balance for 1 $\phi$ / 220V motors used on a 3 $\phi$ / 220V power source .....	5
3.4 How to change solenoid supply voltage ( DC : 24V OR 30V ) .....	5
<b>4. 7-Segment LED Display Mode and Function Keys :</b>	
4.1 Normal mode display .....	6
4.2 Function keys adjustment .....	6
<b>5. General Parameter Adjustment</b>	
5.1 How to enter each parameter mode .....	7
5.2 How to enter parameter value area and make adjustment .....	7
5.3 Machine code adjustment .....	7
5.4 General function parameter .....	8
<b>6. Operation Box</b>	
6.1 C-60M / C-300M Operation box keys definition .....	9
6.2 C-60M parameter adjustment .....	12
<b>7. Error Code / Basic Trouble Shooting</b>	
Error code and measurement .....	13
<b>8. General Parameter List</b>	
8.1 [ Parameter Mode A ] list .....	14
8.2 [ Parameter Mode B ] list .....	16
<b>Appendix A : Connector Panel</b>	
1. HVP-90-4-7W .....	A
2. HVP-90-4-BR (T8) .....	A
3. HVP-90-4-11 (Y6) .....	B
4. HVP-90-4-66 (07) \ (V7) \ (V8) .....	B
5. HVP-90-4-98 .....	C
6. HVP-90-4-DW (LT) (46) .....	C
7. HVP-90-4-ED .....	D

Bottom page : 7-segment display characters compare chart

## 1. Safety Precaution

Please read this manual carefully , also with related manual for the machine head before use. For perfect operation and safety, installing and operating this product by trained personnel is required. Also the following precaution must be taken.

- Turn off the power, unplug the cord and wait 10 minutes before any installing, mounting, or opening the control box cover.
- This product is designed for use with specified sewing machines and must not be used for other purposes.
- Only use Power Voltage indicated on the name plate of the HVP-90 in  $\pm 10\%$  ranges.

※Attention : If the control box is AC 220V system, please don't connect to the AC 380V power outlet, otherwise the error code **E-0.4** will occur. If that happened, please turn off the power switch immediately and check the power voltage. Continue supply the 380V power over 5 minutes might damage the fuses (F1,F3) and burst the electrolytic capacitors (C8,C9,C70) of the power board and even might endanger the person safety.



- To avoid the false operation, please keep the product away from the high electromagnetic machinery or electro pulse generator.
- Don't operate in direct sun light / outdoors area and the room temperature is 45°C above or 5°C under.
- Don't operate near the heater / dew area and the humidity is 30 % less or 95% more.
- Don't operate in dusty / evaporate / combustible gas area, and stay away from corrosive material.
- Avoid power cord being applied by heavy objects or excessive force, or over bend.
- Power cord must keep 3cm or above distance to the V-belt and the pulley.
- To avoid the static interference and current leakage, all grounding must be done correctly.
- Use the correct connector and extension wire when connecting ground wire to Earth and secure it tightly.
- Turning on the machine in the first time, use low speed to operate and check the correct rotation direction.
- During machine operation, don't touch any moving parts.
- All moving parts must use the protective device to avoid the body contact and objects insertion.
- Maintenance and Repairs must be done by the specially trained personnel.
- Don't cover up motor's ventilation, it can cause motor overheated.
- Don't use any objects or force to hit or ram the product.
- All spare parts for repair must be approved or supplied by the manufacturer.

### Danger and caution signs:



Risks that may cause personal injury or risk to the machine are marked with this symbol in the instruction manual.



This symbol indicates electrical risks and warnings.

### Warranty information:

Manufacturer provide a warranty in respect of the products covered for a period of 18 months after the shipping date of the products for any defects arising in the normal course of use of the products by customers.

## 2. Installation and Adjustment :

### 2.1 Motor installation : (Recommend table drill holes)

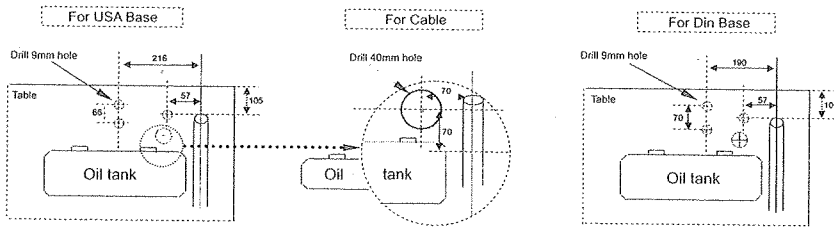

### 2.2 Installation diagram :

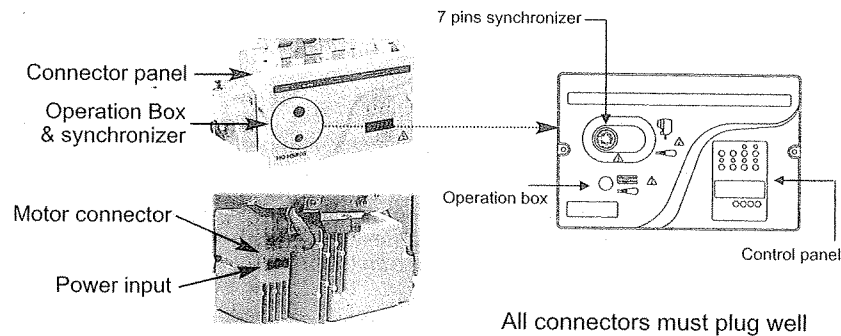
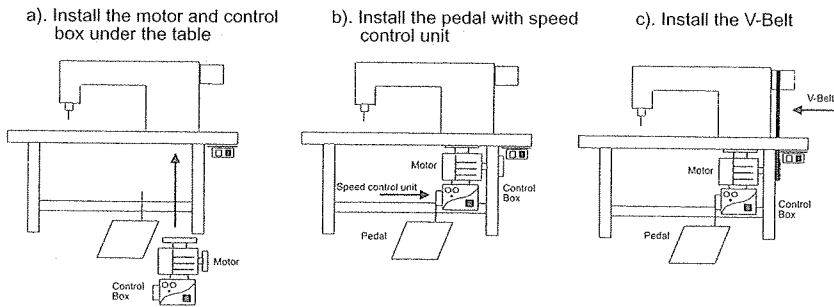

- 1). Pulleys of motor and machine must properly align.
- 2). Cable pass through or under the working table must be secured to avoid rubbing with the V-belt.
- 3). Use the motor base to adjust belt's tension.

### 2.3 Adjustment on the belt cover :

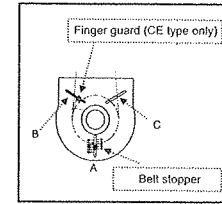

- a). Adjust the belt stopper (A) properly and leave about 5~10mm space from V-belt.
- b). Factory default, finger guard is set at position (B). (for rotation of counterclockwise) For rotation of clockwise, the finger guard must be moved to position (C) and avoiding contact to the V-belt or pulley.

### 2.4 Install and adjust the synchronizer (sensor):

- a). Synchronizer installation : Mounting the Synchronizer onto the flange of machine pulley and fasten the rotor by setting screws.

- b). Synchronizer adjustment :

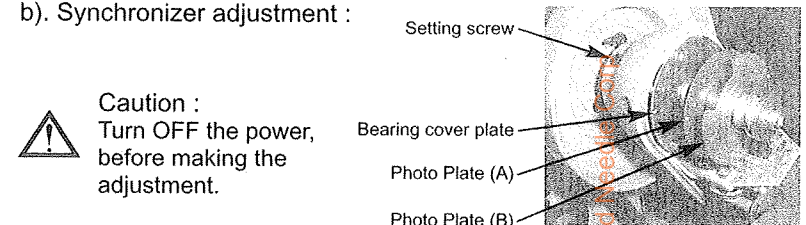

Needle up position : Rotate the machine pulley to reach mechanical needle up position and turn the photo plate (A) until its red mark is aligned with the red mark on the bearing cover plate.

Needle down position : Rotate the machine pulley to reach mechanical needle down position and turn the photo plate (B) until its blue mark is aligned with the red mark on the bearing cover plate.

Note : instruction above is the standard adjustment. If you feel the position wasn't accurate, please do the fine tuning by yourself.

### 2.5 Speed control unit adjustment : Components of speed control unit : see figure

- A : Spring for toeing forward force adjustment
- B : Bolt for heeling backward force adjustment
- C : Treadle / Pedal arm
- D : Pitman rod for Treadle / Pedal

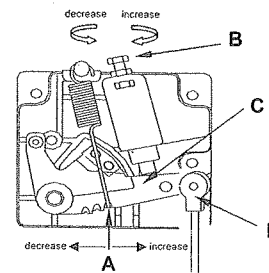

Term of adjustment	After adjustment
1 Toeing forward force adjustment	Spring A move to right = force increased Spring A move to left = force decreased
2 Heeling backward force adjustment	Bolt B turn ← = force decreased Bolt B turn → = force increased
3 Treadle stroke adjustment	Rod D secure at right = stroke is longer Rod D secure at left = stroke is shorter

### 3. Power Connection and Grounding :

#### 3.1 Single phase and three phase connection :

Green / yellow wire is the ground wire.

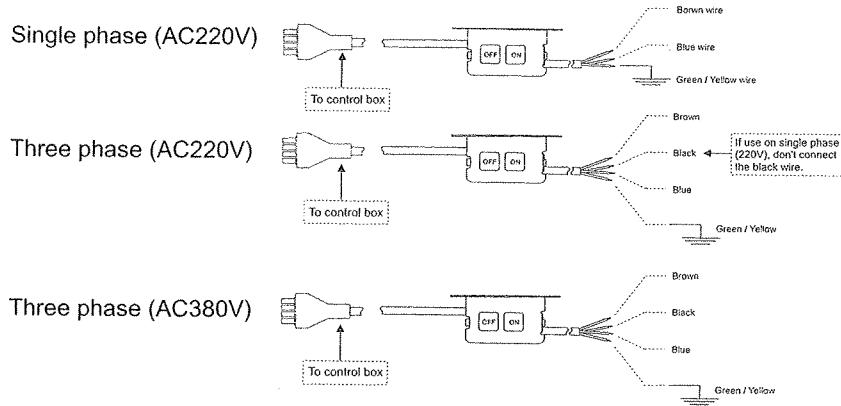

- 1). When a three phase 220V servo motor use a on single phase 220~240V power, only connect brown and blue wires. Use insulating tape to wrap up the unused black wire, in order to prevent the current leakage.
- 2). Green / Yellow wire must do the grounding.

#### 3.2 How to connect a 1 $\phi$ / 220V power from a 3 $\phi$ / 380V power source :



**Caution :** If the power source does not have the neutral point, then this 1  $\phi$  / 220V servo motor is not suitable for this connection. Plesae ask supplier for our 3  $\phi$  / 380V servo motor.

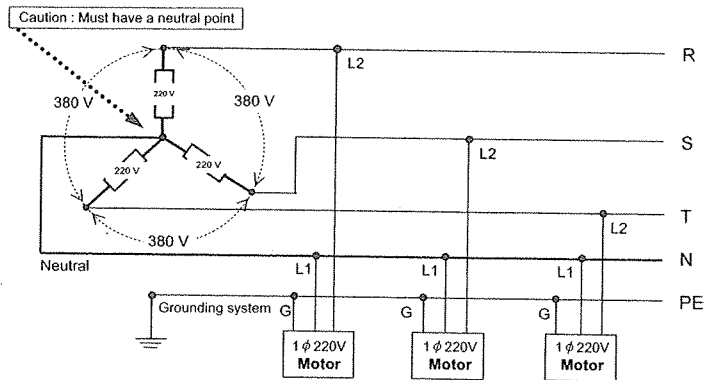

#### 3.3 The load balance for 1 $\phi$ / 220V motors used on a 3 $\phi$ / 220V power source :

See the following figure for the load balance.

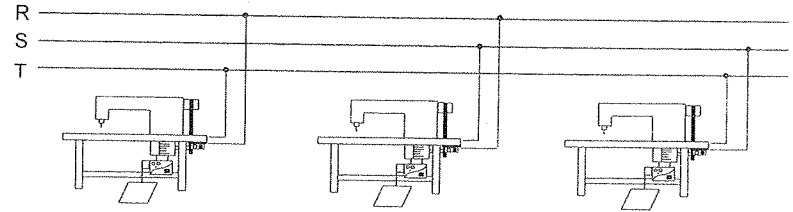

#### 3.4 How to change solenoid supply voltage (DC: 24V OR 30V) :

The JP1 is for 30 V and JP2 is for 24 V.



**Caution 1 :** Before making the switch, check the machine head's Solenoid specification.



**Caution 2 :** Turn off the power and wait 10 min. before opening the cover, then make the change.

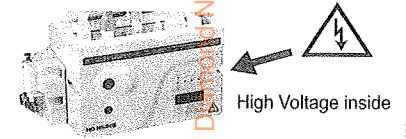

#### Step 1

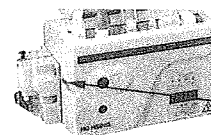

The power board layout :

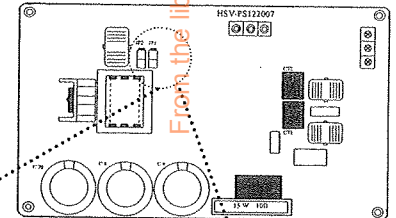

#### Step 2

**24V jumper setting**

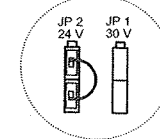

**30V jumper setting**

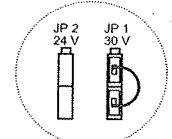

## 4.7-Segment LED Display Mode and Function Keys :

### 4.1 Normal mode display :

Power ON = Normal mode : See the diagram for lockstitch machine and interlock stitch machine display.

Lockstitch machine

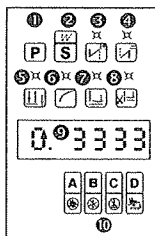

- ① Enter parameter / Parameter increment
- ② Free sewing \ Bar tacking \ Constant stitch sewing / Enter parameter value / Saving
- ③ Start back tacking / Parameter increment
- ④ End back tacking / Parameter decrement
- ⑤ Needle up at machine stop
- ⑥ Soft start
- ⑦ Presser foot up at machine stop
- ⑧ Presser foot up after trimming
- ⑨ 7-segment LED
- ⑩ Setting key for Number of stitches / Number of sections / Number of times

Interlock stitch machine

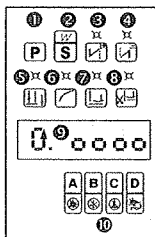

- ① Enter parameter / Parameter increment
- ② Enter parameter value / Saving
- ③ Parameter increment
- ④ Parameter decrement
- ⑤ Needle up at machine stop
- ⑥ Soft start
- ⑦ Presser foot up at machine stop
- ⑧ Presser foot up after trimming
- ⑨ 7-segment LED
- ⑩ Special function keys



### 4.2 Panel function keys adjustment :

#### Lockstitch machine functions

- ② Select bar tacking function, LED show **0.5 4 4** . Press ⑩ **A B C D** key to adjust the stitches and times.
- ② Select constant stitch sewing, LED show **0.P 1 1 5** . Press ① **A B C D** key to adjust the stitches and times.
- ③ ④ Select start / back tacking, LED show **0.3333** . Press ⑩ **A B C D** key to adjust the stitches.
- ⑤ ⑥ ⑦ ⑧ Function selection, LED above the key lighten means function enabled.





#### Interlock stitch machine functions

- ⑩ Special functions selection : A = half heeling \ B = trimming \ C = wiping \ D = start constant stitch sewing.

Press any of A \ B \ C key, the icon  show up which mean the corresponding function been disable. Except the **D** key, the icon  show up which mean the start constant stitch sewing been enable.

## 5.General Parameter Adjustment :

### 5.1 How to enter each parameter mode :

Parameter mode	Operating way	First display	keys	Range of parameter
Level 1 [Mode A]	At [Normal mode] Press <b>P</b> key	<b>001. H</b>	 	# 001~046
Level 2 [Mode B]	<b>P</b> + Turn-on power	<b>047.MAC</b>	 	# 001~122

### 5.2 How to enter parameter value area and make adjustment :

Step 1 : Enter the parameter level and find the parameter.

Step 2 : After find the parameter, press the **S** key to enter the parameter value area. Press any of **A B C D** key to adjust the parameter value.

Terms for A \ B \ C \ D keys in the parameter value :

TERMS	KEY VALUE	<b>A</b>	<b>B</b>	<b>C</b>	<b>D</b>
		IN TERMS OF SPEED	1000 spm	100 spm	10 spm
IN TERMS OF ANGLE	-----	100°	10°	1°	
IN TERMS OF TIMING		1000 ms	100 ms	10 ms	10 ms
IN TERMS OF FUNCTION				Function Swap	Function Swap

∴ Other than the function selection, each press of the key will start change the value from 0 to 9

Note : After value changed, press the **S** key to save the value, otherwise they will lost after turning power off.

### 5.3 Machine code adjustment :

☆ Machine code [047. MAC] : Enter the parameter level 2, the first parameter is the machine code. Then press the **S** key to enter the parameter value area. Press A \ B \ C \ D key to adjust the machine code.

After adjustment press the **S** key to save the setting.

- Note :
1. The [047. MAC] machine code setting might be varies which depends on the machine head brand and model.
  2. Wrong machine code setting might cause machine head operation abnormal or damaged.
  3. After save the machine code, the corresponding parameters will load the default value automatically.

### 5.4 General function parameter :

Follow the steps on section 5.1 、 5.2 to adjust these parameters.

Speed function		Back tacking	
[001 .H]	Maximum sewing speed ( spm )	[014.SBT]	Start back-tacking function selection
[004 .N]	Start back-tacking speed ( spm )	[015.SBA]	Setting stitches A of Start back-tacking
[005 .V]	End back-tacking speed ( spm )	[016.SBB]	Setting stitches B of Start back-tacking
[006 .B]	Bar-Tacking Speed ( spm )	[017.SBN]	Setting turns of Start Back-tacking
[007 .S]	Soft start speed ( spm )	[021.EBT]	End back-tacking selection
[009 .A]	Automatic constant-stitch sewing speed ( spm )	[022.EBC]	Setting stitches C of End back-tacking
[122.HL]	Upper limit of maximum speed ( spm )	[023.EBD]	Setting stitches D of End back-tacking
		[024.EBN]	Setting turns of End back-tacking
Bar tacking / Constant stitch		Wiper / Trimmer	
[032.BAR]	Bar-tacking selection	[040.WON]	Wiper function selection
[033.BRC]	Setting stitches of Bar-tacking	[092. W1]	Delayed timing prior to wiper engaged
[034.BRN]	Setting turns of Bar-tacking	[093. W2]	Setting timing of wiping
[010.ACD]	Automatic sewing End back-tacking	[041. TM]	Trimmer function selection
[038. PM]	Constant-stitch sewing selection	[082. T1]	Delayed timing prior to trimmer engaged
[039. PS]	Setting stitches for section of Constant-stitch sewing	[083. T2]	Trimming time

Automatic presser foot	
[064. FO]	Full-On time setting for foot lifting solenoid
[065. FC]	Duty cycle time setting for foot lifting solenoid
[066. FD]	Running-Delay time setting
[070.HHC]	Cancel foot lifting at half-heeling pedal

- Note :
1. When motor running, the parameter area is locked and prohibited for access. The parameter only can be adjust when motor stop.
  2. When press the [P] key to access parameter area, the [P] key can also act as the parameter increment key.
  3. When adjust the parameter, you must fully understand the function usage and the setting effects. If you have doubt or question, please ask the customer service or technical support to help you. Don't try to adjust blindly.
  4. Caution! Wrong setting of the parameter might cause the abnormal operating and damage the sewing machine.

### 6.Operation Box :

6.1 C-60M / C-300M Operation box keys definition :  
(C-300M don't have parameter setting function)

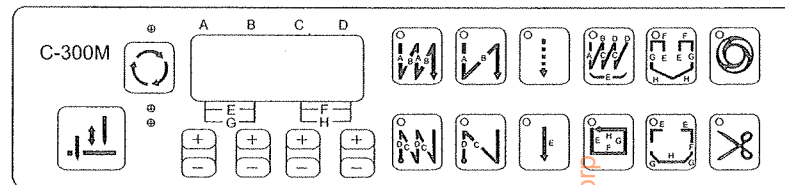
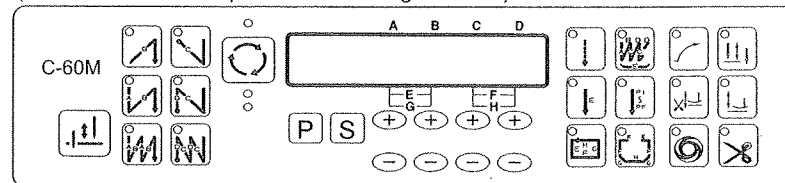

Function	Key	Operation of Sewing Machine
Start / End Back Tacking Selection		Double start back tacking (A,B sections)
		Single start back tacking (A,B sections)
		Half start back tacking (B section) (C-60M)
		Double end back tacking (C,D sections)
		Single end back tacking (C,D sections)
		Half end back tacking (C section) (C-60M)
Constant Stitch Sewing		1). When the treadle is toeing down, Constant-stitch Sewing E、F、G or H performed section by section. 2). If the treadle returns to neutral intermediately in any one section, the machine will stop immediately. After the treadle toed down again, the balanced stitches of E、F、G or H goes on. 3). If the parameter [010.ACD] is set ON, the machine will not stop and automatically start trimming cycle and end back tacking at the end of the last section E or H. 4). When use P1~PF function, P1~P4 default setting is 15 stitches, other unused sections must set 0 stitch.

Free Sewing		<p>1). As the treadle is toeing down, machine will start sewing. If the treadle returns to neutral, machine will stop immediately.</p> <p>2). When the treadle is heeling back, the trimming cycle will be finished automatically.</p>
Bar Tacking		<p>When the treadle is toeing down, all the seams of Bar tacking in A \ B \ C \ D sections will be completed with E times, and the trimming cycle will be finished automatically.</p> <p>Note : When the bar tack sewing start, it will not stop until the trimming cycle finished, except for the treadle heeled back to cancel the action.</p>
Stitch Setting Selection		<p>A \ B \ C \ D -- stitch setting range in 0 ~ F (Note) E \ F \ G \ H -- stitch setting range in 0 ~ 99</p> <p> A B C D 4 4 4 4 ... A=B=C=D=4 stitches</p> <p> A B C D 1 0 1 0 ... E=F=10 stitches</p> <p> A B C D 1 5 1 5 ... G=H=15 stitches</p> <p>∴ Press  key to select : Top A \ B \ C \ D Middle E \ F Bottom G \ H</p>
Needle UP / Forward Stitch Correction		<p>1). In Free sewing: One touch of this key act as stitch correction. (half stitch forward)</p> <p>2). In constant-stitch sewing : (In Bar-tack sewing, it act as needle up)</p> <p>a. If sewing stops intermediately in one section, one press of this key will raise the needle to up position.</p> <p>b. If sewing stops at the end of section, one press of this key will correct one stitch forward.</p>
One-Shot Sewing (AUTO)		<p>1). In Free sewing and Bar-tack sewing : One press of this key make beep sound but no function, also LED does not lighten up.</p> <p>2). In Constant-stitch sewing :</p> <p>a. One-shot to the pedal, automatic performed number of stitches of E \ F \ G \ H sections.</p> <p>b. Toeing down the pedal again to finish the rest sections until it finish the pattern.</p>

Trimming Cycle Selection		Enable or disable the trimming cycle.
Soft Start (C-60M)		<p>1). When function turn ON, soft start only activated at first run of motor start. After trimming cycle finish, it will activate again on next motor start.</p> <p>2). Speed of the soft start can be set by parameter [007 .S]</p> <p>3). Number of stitches can be set by parameter [008.SLS]</p>
Needle UP / DOWN when Motor Stop (C-60M)		<p>Needle stop setting</p> <p>LED ON= Stop at UP position</p> <p>LED OFF=Stop at DOWN position</p>
Presser Foot UP / DOWN after Trimming Cycle (C-60M)		<p>Presser Foot action after trimming</p> <p>LED ON= Automatic lift the presser foot after trimming.</p> <p>LED OFF=Presser foot not active after trimming.</p>
Presser Foot UP / DOWN when Motor Stop (C-60M)		<p>Presser foot action when motor stop</p> <p>LED ON=Motor stop, presser foot goes up automatically.</p> <p>LED OFF=Presser Foot not active when motor stop.</p>
Value Increment Key		A \ B \ C \ D section value increment key, range in 0~ F. (Note) E \ F \ G \ H section value increment key, range in 0~99.
Value Decrement Key		A \ B \ C \ D section value decrement key, range in 0~ F. (Note) E \ F \ G \ H section value decrement key, range in 0~99.
Enter parameter area / Parameter increment		Press and hold this key for 2 second to enter parameter area. Also act as parameter increment key.
Enter parameter value / Saving		Press this key in parameter area to enter parameter value area. Also act as the parameter value saving key.

Note : Stitches setting of A \ B \ C \ D sections correspond to the alphabet.  
A=10 \ B=11 \ C=12 \ D=13 \ E=14 \ F=15 stitches

## 6.2 C-60M parameter adjustment :

### 6.2.1 How to access [Parameter Mode A] parameters total from 001~046

a. In [Normal mode] area, press **[P]** key to access the mode A.

b. Use **[←]** or **[→]** key to find the parameter [002.PSL]  
c. Use **[S]** key to access [value area]

d. Use the **[←]** **[→]** key under the **[A]****[B]****[C]****[D]** area to set the value.  
e. Press **[S]** key to save the value.

### 6.2.2 How to access [Parameter Mode B] parameters total from 047~122

a. If machine ON, Power OFF first.

b. Press and hold **[P]** key and turn on the power to access the first parameter code [047.MAC] of [parameter mode B]

c. Use **[←]** or **[→]** key to find the parameter [048.N12]  
d. Use **[S]** key to access [value area]

e. Use the **[←]** **[→]** key under the **[A]****[B]****[C]****[D]** area to set the value.  
f. Press **[S]** key to save the value.

Note : After press **[S]** key to save the value, it also automatic go back to normal mode.

### 6.2.3 Terms for C-60M in parameter value :

Terms for A · B · C · D area which adjust by the **[←]** **[→]** key in the parameter value.

Terms	Key			
	A	B	C	D
IN TERM OF SPEED	1000 spm	100 spm	10 spm	1 spm
IN TERM OF ANGEL	-----	100°	10°	1°
IN TERM OF TIMMING	1000 ms	100 ms	10 ms	10 ms
IN TERM OF FUNCTION				Mode selection

∴ Other than the mode selection, each press the **[←]** or **[→]** key will circling the value from 0 to 9, the total value can't be set lower or greater than the ranged value. When the value is the maximum ranged value, press any **[←]** **[→]** key of the A · B · C · D area will change the value back to the minimum ranged value.

- Note : 1. After value changed, press the **[S]** key to save the value, otherwise they will lost after turning power off.  
2. Under the parameter mode, the function keys are invalid.

## 7. Error Code / Basic Troubleshooting :

### 7.1 Error Code and measurement:

Error Code	Cause of The Problem	Status and Measurement
ER0.1	1. Power module detected error. 2. Abnormal over current or voltage occurred.	Motor and machine will be shutting down. Please check the power module. Please check the power board over current circuitry.
ER0.4	1. When power on, detected high voltage. 2. Connect the wrong voltage or supply power is too high. 3. Aluminum casing resistor for the brake circuit is defective or power board F2 fuse burst.	Motor and machine will be shutting down. Please check the AC power (Too high) ※ If control box is AC 220V system, don't use the AC 380V power voltage, otherwise the LED will display ER0.4 after 2 second of power ON. If continue supply the 380V power, the electrolytic capacitors (C8,C9,C70) of power board will burst open over a period of time and cause the fuses (F1,F3) of power input open circuit. Please check the power board. Please check the aluminum casing resistor and power board F2 fuse.
ER0.5	1. When power on, detected low voltage. 2. Connect the wrong voltage or supply power is too low.	Motor and machine will be shutting down. Please check the AC power. (Too low) Please check the power board.
ER0.7	1. Bad connection at the motor connector. 2. Synchronizer (sensor) signal error. 3. Machine locked or object stuck in the motor pulley. 4. Sewing material is too thick.	Motor and machine will be shutting down. Please check the motor or motor connectors' connection. Please check the synchronizer ( sensor ) and it's signal. Please check machine head to see if objects stuck in the motor pulley, or rotate not smoothly.
ER0.8	Operation box linked to CPU interface had communication error.	Motor and machine will be shutting down. Please check the operation Box.
ER0.9	1. Machine solenoid shorted. 2. Main board's power transistor is faulty.	Motor still can run, but all output signals and operation box's pattern sewing function will be invalid. Please check machine's solenoids, or the resistance value is 2.1Ω less. Please check all the power transistors, which related to solenoid.
ER0.11	1. If parameter [121.ANU] is set ON, but auto needle up is malfunction when the power turned on.	Motor and machine will be shutting down. Please check synchronizer's up position's signal. Please check control box. Please check machine head to see if objects stuck in motor pulley, or pulley rotate not smoothly.
ER0.12	Power on, no synchronizer signal or not connected (valid for under table motor)	Automatic starts the clutch mode. Please check the synchronizer. (also check the connection and model)
ER0.13	Motor rotation icon in LED is halting and not moving. 1. Safety switch is either faulty or bad connection. (For interlock stitch or blind stitch machine). 2. Parameter [075.SFM] setting not match the machine head model.	Motor stops. Please check the safety switch. Please check parameter table on [075.SFM] setting, make sure it match machine head's safety switch.



## 8. General Parameter List :

### 8.1 [ Parameter Mode A ] list

Parameter Code	Parameter Function	Range / Selection	Description
[001. H]	Maximum sewing speed (spm)	50~9999	Maximum speed adjustments
[002.SLM]	Soft start mode selection	A / T	A : Toe down the pedal, soft start automatic running T : After trimming, soft start automatic running on next sewing
[003.CNR]	Counter ratio selection	1~100	Setting the multiple to the value of [042. CUD]
[004. N]	Start back-tacking speed (spm)	50~8000	Start back-tacking speed adjustments
[005. V]	End back-tacking speed (spm)	50~8000	End back-tacking speed adjustments
[006. B]	Bar-Tacking Speed (spm)	50~8000	Repeat bar-tacking speed adjustments
[007. S]	Soft start speed (spm)	50~2000	Soft start speed adjustments
[008.SLS]	Stitch numbers for soft start (stitch)	0~99 stitches	Soft start stitches setting
[009. A]	Automatic constant-stitch sewing speed (spm)	50~8000	Valid only at the auto pattern sewing or one shot signal (SH) active
[010.ACD]	Automatic sewing End back-tacking	ON / OFF	Only at the last seam of pattern sewing O N : Valid. OFF : Invalid.
[011.RVM]	Back-tacking mode selection	J / B	J = JUKI mode , B = BROTHER mode. J : Active when motor stop or running B : GActive only when motor running
[012.SMS]	Mode selection for start back-tacking.	A / M / SU / SD	Start back-tacking mode selection : A : One shot sewing M : Pedal control and motor can stop at middle way. SU : One shot sewing but motor stops at needle up by [027.CT] timer at end of each seam. SD : One shot sewing but motor stops at needle down by [027.CT] timer at end of each seam.
[013.TYS]	Mode selection at the end of Start back-tacking	CON / STP / TRM	CON : At the end of Start back-tacking, it continues sewing if pedal pressed or START signal on (standing operation) STP : At the end of Start Back-Tacking, machine stops and must re-start by pedal command. TRM : Making the trimming cycle once the Start Back-Tacking finished. ( Mini Bar tacking )
[014.SBT]	Start back-tacking function selection	ON / OFF	Valid only when the operation panel disconnected. O N : Perform OFF : Not perform
[015.SBA]	Setting stitches A of Start back-tacking	0~15 stitches	Start back-tacking stitches setting , [014. SBT] = ON valid
[016.SBB]	Setting stitches B of Start back-tacking	0~15 stitches	
[017.SBN]	Setting turns of Start Back-tacking	0~4 turns	Setting the seam times of Start back-tacking , [014. SBT] = ON valid
[018.BT1]	Stitch balance for Start Back-tacking 1	0~F	BT1=0:Invalid,1-8:Increase stitches of reverse seam, 9-F:Increase stitches of forward seam BT2=0:Invalid,1-8:Increase stitches of forward seam, 9-F:Increase stitches of reverse seam
[019.BT2]	Stitch balance for Start Back-tacking 2		
[020.SME]	Mode selection for End back-tacking	A / SU / SD	End back-tacking mode selection : A : One shot sewing. SU : One shot sewing but machine stops up position by [027. CT] timer at the end of each seam. SD : One shot sewing but machine stops down position by [027. CT] timer at the end of each seam.
[021.EBT]	End back-tacking selection	ON / OFF	Valid only when the operation panel disconnected. O N : Perform OFF : Not perform
[022.EBC]	Setting stitches C of End back-tacking	0~15 stitches	End back-tacking stitches setting , [021.EBT] = ON valid
[023.EBD]	Setting stitches D of End back-tacking	0~15 stitches	

[024.BEN]	Setting turns of End back-tacking	0~4 times	Setting the seam times of End back-tacking , [021. DEB] = ON valid
[025.BT3]	Stitch balance for End Back-tacking 3	0~F	BT3=0:Invalid,1-8:Increase stitches of reverse seam, 9-F:Increase stitches of forward seam BT4=0:Invalid,1-8:Increase stitches of forward seam, 9-F:Increase stitches of reverse seam
[026.BT4]	Stitch balance for End Back-tacking 4		
[027. CT]	Setting time interruption at each section end of Back-Tacking. (ms)	0~990 ms	[012. SMS] [020. SME] [031. SMB] = SU / SD setting valid. Corner stop timer, valid only at [012. SMS] [020. SME] [031. SMB] setting SU/SD.
[028.SB5]	15 stitches plus on Start/End back-tacking.	ON / OFF	Additional 15 stitches are added to the Start and End back-tacking stitches function selection. ON : Valid. OFF : Invalid
[029.SB9]	0~99 stitches plus on Start/End back-tacking.	0~99 stitches	Additional setting stitches are added to the Start and End back-tacking stitches.
[030.BCC]	Added 1 stitch to the C segment of End back-tacking	ON / OFF	Added 1 stitch to the C segment of End back-tacking function selection. ON : Valid / OFF : Invalid
[031.SMB]	Mode selection for Bar-tacking	A / M / SU / SD	Bar-tacking mode selection : A : One shot sewing. M : Pedal control and motor can stop at middle way. SU : One shot sewing but motor stops at needle up by [027. CT] timer at end of each seam. SD : One shot sewing but motor stops at needle down by [027. CT] timer at end of each seam.
[032.BAR]	Bar-tacking selection	ON / OFF	Valid only when the operation panel disconnected. ON : Perform / OFF : Not perform.
[033.BRC]	Setting stitches of Bar-tacking	0~99 stitches	One setting for all seams. [032. BAR] = ON valid.
[034.BRN]	Setting turns of Bar-tacking	0~15 turns	The seam times of Bar-tacking , [032. BAR] = ON valid.
[035.BT5]	Stitch balance for Bar-tacking 5	0~F	BT5=0:Invalid,1-8:Increase stitches of reverse seam, 9-F:Increase stitches of forward seam BT6=0:Invalid,1-8:Increase stitches of forward seam, 9-F:Increase stitches of reverse seam
[036.BT6]	Stitch balance for Bar-tacking 6		
[037.SMP]	Mode selection for Constant-stitch sewing	A / M	A : One shot sewing. M : Pedal control and motor can stop at middle way.
[038. PM]	Constant-stitch sewing selection	ON / OFF	Valid only when the operation panel disconnected. ON : Perform. / OFF : Not perform.
[039. PS]	Setting stitches for section 1~4 of Constant-stitch sewing Setting stitches for section 5~F of Constant-stitch sewing	0~250 stitches	Stitches setting of seam P1~P4. [038. PM] = ON valid. Stitches setting of seam P5~PF. [038. PM] = ON valid.
[040.WON]	Wiper function selection	ON / OFF	ON : Enable / OFF : Disable
[041. TM]	Trimmer function selection	ON / OFF	ON : Enable / OFF : Disable
[042.CUD]	Count mode selection (For Bobbin Thread or Sewing Piece)	NOP / U / D US / DS UT / DT UTS / DTS	NOP : The counter is invalid. U : Count up by stitches. When count over, counter will be auto-reset. D : Count down by stitches. When count over, counter will be auto-reset. US : Count up by stitches. When count over, motor stops and the counter must be reset by the external switch or the A key on the front panel. DS : Count down by stitches. When count over, motor stops and the counter must be reset by the external switch or the A key on the front panel. UT : Count up by trimming. When count over, counter will be auto-reset. DT : Count down by trimming. When count over, counter will be auto-reset UTS : Count up by trimming. When count over, motor stops and the counter must be reset by the external switch or the A key on the front panel. DTS : Count down by trimming. When count over, motor stops and the counter must be reset by the external or the A key on the panel.
[043. UD]	Setting the count	1~9999	Count setting. (Note : The real number = the value of [003.CNR] X [043.UD] ,when [042.CUD] = U,D,US,DS valid only.)
[044. PN]	Display the current count	0~9999	Display the current count of [043.UD]
[045. SP]	Sewing speed	---	Showing the current sewing speed.
[046.DIR]	Direction of motor rotation	CW / CCW	CCW : Counterclockwise / CW : Clockwise.

### 8.2 [Parameter Mode B] list

Parameter Code	Parameter Function	Range / Selection	Description
[047.MAC]	Machine Code	0~101	Machine code switchover
[049.SPD]	Machine's pulley dimension	1~250	Setting machine pulley size when [051.PL] = ON valid.
[050.MPD]	Motor's pulley dimension.	1~250	Setting motor pulley size when [051.PL] = ON valid.
[054. BK]	Motor braked at normal stop	ON / OFF	ON : Enable / OFF : Disable.
[057.TRU]	Motor stops with a reverse angle after trimming	ON / OFF	ON : Enable / OFF : Disable.
[058.TR8]	Setting the angles of [057. TRU]	1~360°	Valid only when [057. TRU] = ON
[064. FO]	Full-On time setting for foot lifting solenoid (ms)	0~990	For solenoid pulling torque adjustment.
[065. FC]	Duty cycle time setting for foot lifting solenoid (%)	10~90 %	For solenoid pulling torque adjustment. Note : Wrongly adjustment will cause the solenoid unable to lift or over-heating.
[066. FD]	Running-Delay time setting	0~990	If foot lifter is installed, set 100 ms min. to ensure the presser foot will come down first.
[070.HHC]	Cancel foot lifting at half-heeling pedal	ON / OFF	ON : No foot lifting at half-heeling. (but full-heeling can operate foot lifter) OFF : Operate foot lifting at half-heeling.
[075.SFM]	Safety switch protection mode	NC / NO	NO : Normal open. When signal at close, motor immediately stops and rotation symbol will stop. NC : Normal close. When signal at open, motor immediately stops and rotation symbol will stop.
[082. T1]	Delayed timing prior to trimmer engaged (ms)	0~990 ms	Valid for [079. LTM] = T4/TK/TS/T7.
[083. T2]	Trimming time (ms)	0~990 ms	Valid for [079. LTM] = T1/T3/T4/TK/TS/T7.
[086. L1]	Delayed timing prior to tension release engaged (ms)	0~990 ms	Valid for [080. LLM] = L4/LK/LS/L7.
[087. L2]	Timing of tension release (ms)	0~1500 ms	Valid for [080. LLM] = L1/L3/L4/LK/LS/L7.
[092. W1]	Delayed timing prior to wiper engaged (ms)	0~980 ms	Time setting between needle up to wiper active.
[093. W2]	Setting timing of wiping (ms)	0~9990 ms	Wiper ON timer setting.
[094. WF]	Delayed timing prior to foot lifter engaged (ms)	0~990 ms	Timer setting between wiper OFF to presser foot ON.
[114.UEG]	Needle UP position stop angle	5~180°	Adjust the needle up stop position.
[116.DRU]	Reverse angles through Needle down and up	1~360°	Valid only when [078. TRM] = RK mode Motor reverses from needle down, and stops at the needle upper dead point.
[121.ANU]	Needle goes up as power turned ON	ON / OFF	ON : Automatic needle UP at power on. OFF : Function invalid
[122. HL]	Upper limit of maximum speed (spm)	50~9999	The motor's maximum speed setting

### 附錄 A : / APPENDIX A (HVP-90-3-XX 的型號是無option D) 端子座配置圖 / CONNECTOR DIAGRAM (HVP-90-3-XX model without option D)

#### 1 HVP-90-4-7W:

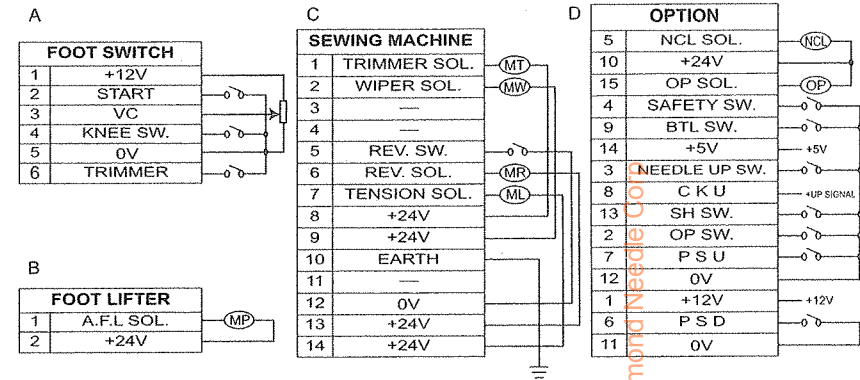
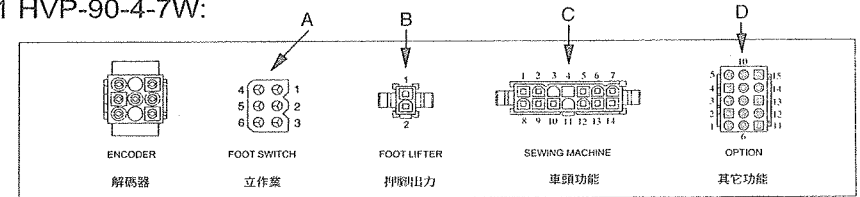

#### 2 HVP-90-4-BR (T8) :

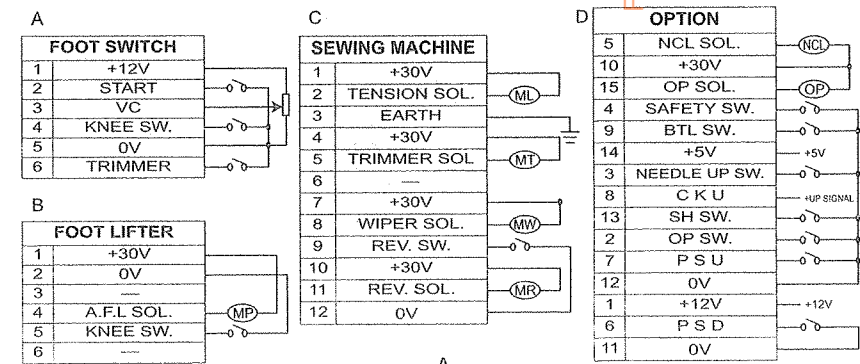
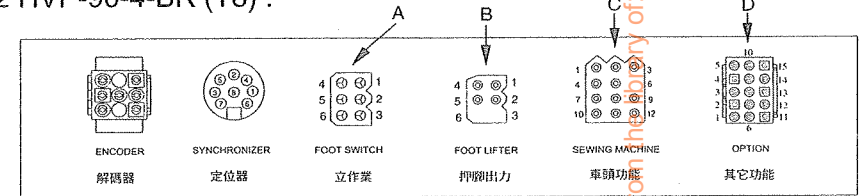

3.HVP-90-4-11(Y6):

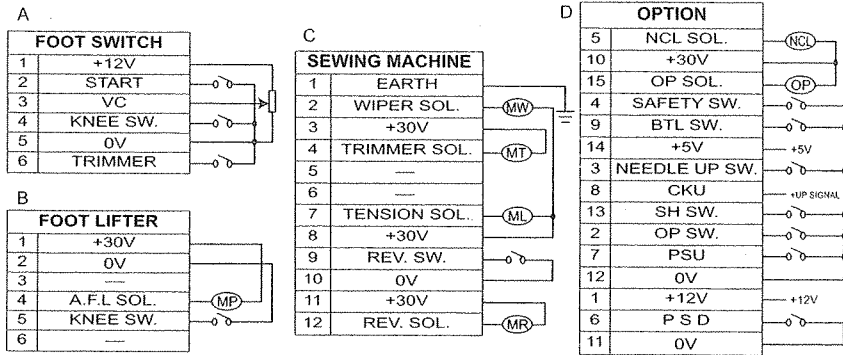
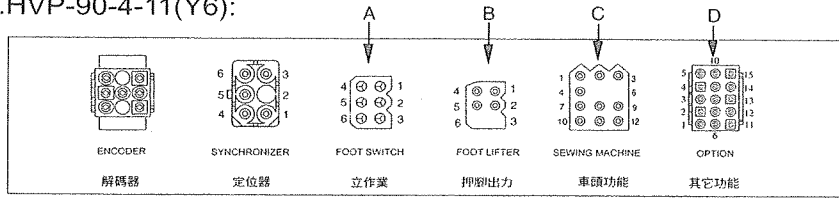

4.HVP-90-4-66: (07) (V8) (V7):

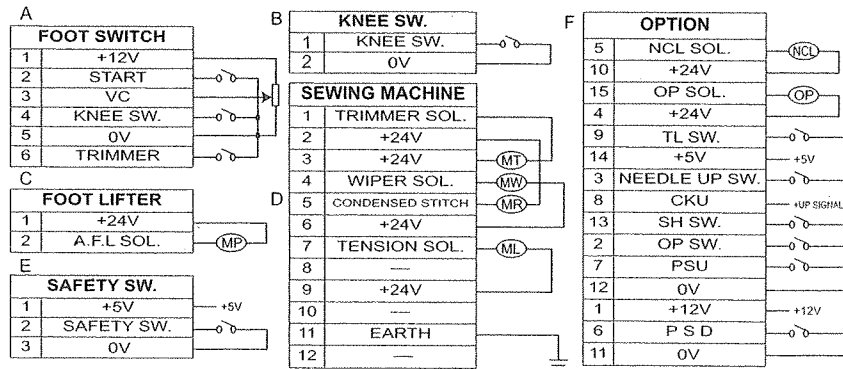
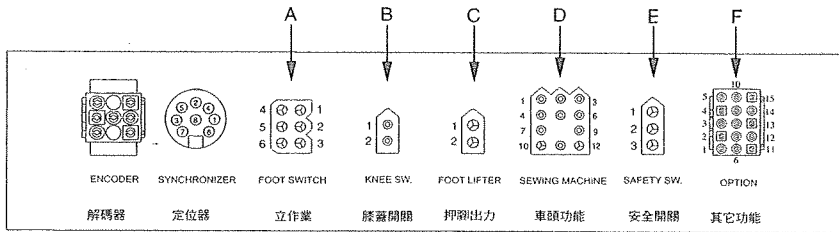

5.HVP-90-4-98:

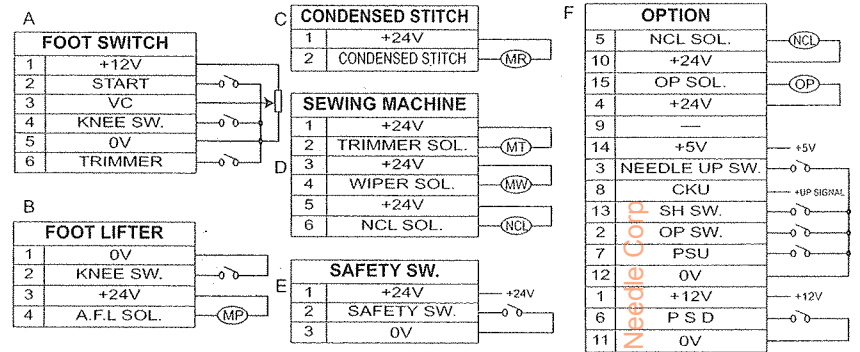
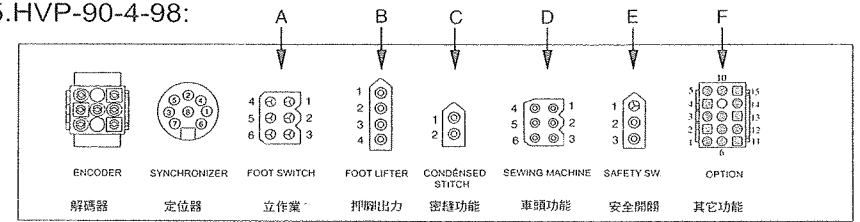

6.HVP-90-4-DW (46) (LT):

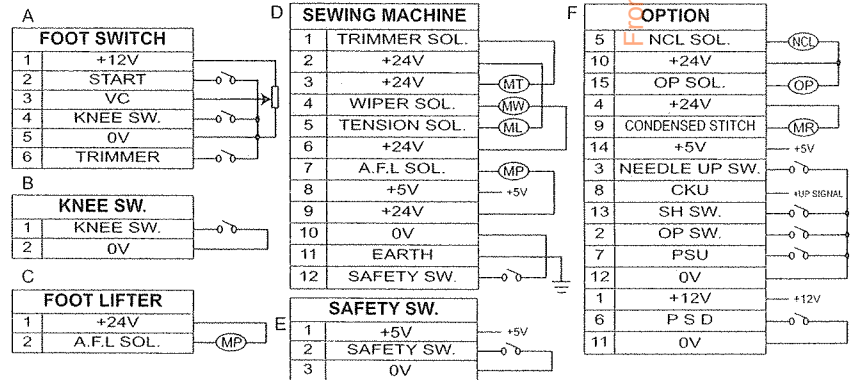
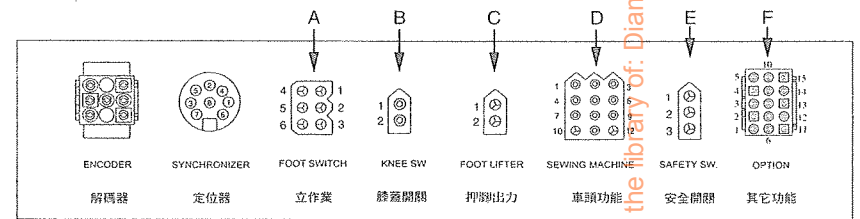

7.HVP-90-4-ED:

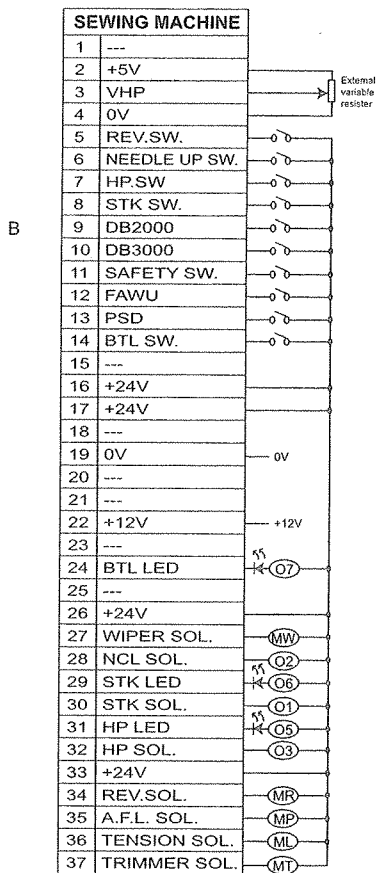
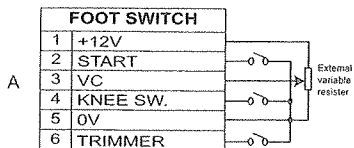
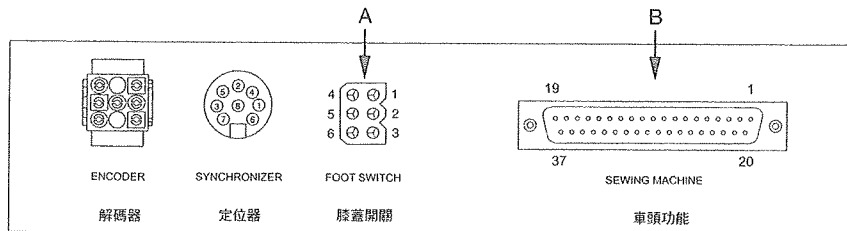

D